

Description

The centrally located Drain/Vent port on the Megaplast™ CD housing head provides for efficient and rapid drainage when mounted with the bowl up, and efficient venting when mounted in the bowl down position.

The Megaplast CD has the same head mounting position design and dimensions as the Pall FlexBowl™ Housing. The comparable flat head design allows for more equipment design installation options.

The housings are designed to meet the stringent cleanliness requirements of ultrapure applications by using high purity PFA for all wetted components.

The Megaplast G2 CD housings are available in 102 mm, (4 in), 254 mm, (10 in), and 508 mm, (20 in) sizes. The 254 mm, (10 in) housing is designed to fit standard filter cartridges with a diameter of up to 82.5 mm, (3.25 in).

A selection of standard semiconductor industry inlet and outlet connection fittings are offered in different sizes and styles.



Features & Benefits

- Optimized drainage and venting designs
- High-purity design
- Metal-free construction
- High temperature capability
- Closure nut is free floating

Specifications

Materials of Construction

Components	Materials
Bowl	High-purity PFA
Head	High-purity PFA
Closure nut	PVDF
O-ring ^{1,2}	PFA encapsulated fluorocarbon elastomer

¹ All fluoropolymer materials made without PFOA.

² Other O-ring options available.

Configuration	T-flow
Maximum Operating Temperature	95 °C / 203 °F
Maximum Operating Pressure of Housing	0.56 MPaG < 30 °C / 81 psig @ 86 °F 0.38 MPaG < 60 °C / 55 psig @ 140 °F 0.28 MPaG < 95 °C / 41 psig @ 203 °F

Dimensions

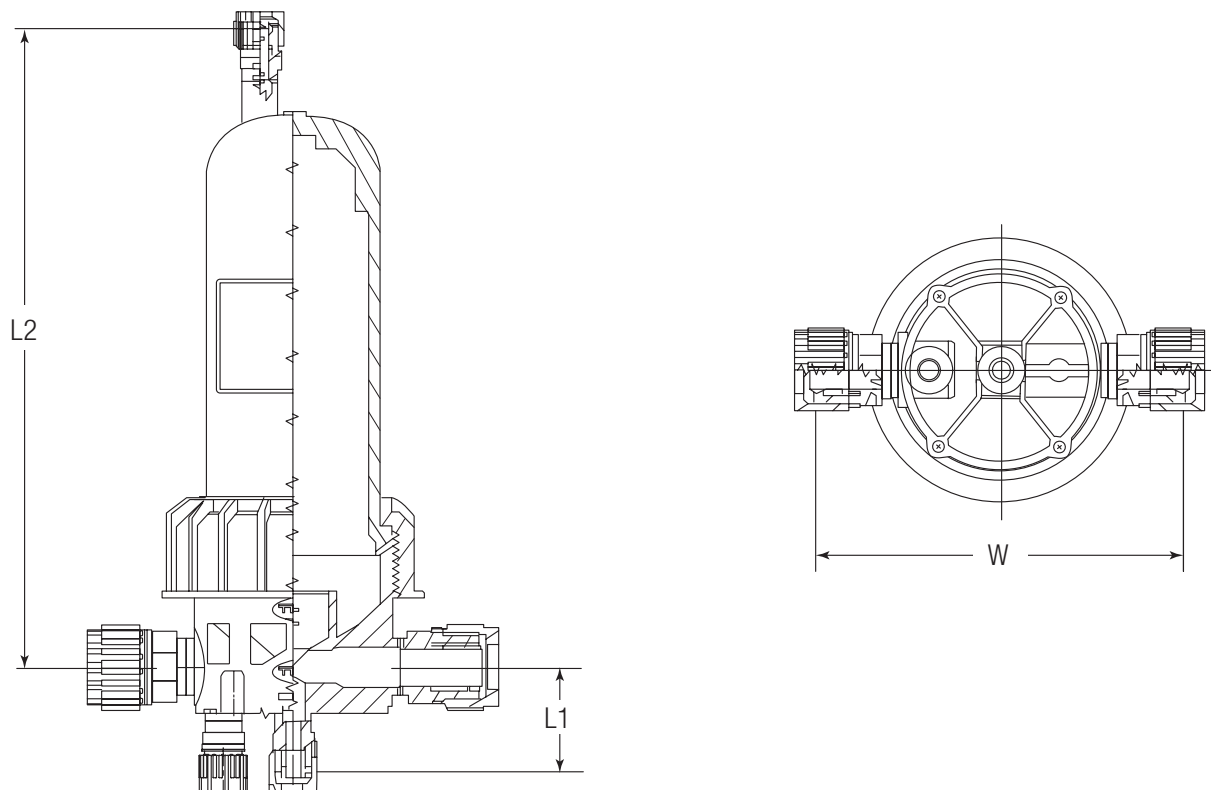

Part number	L1	L2	W
PFCD1F128SPH1B	64.5 mm (2.54 in)	388.6 mm (15.3 in)	218.9 mm (8.62 in)
PFCD1F168SPH1B	64.5 mm (2.54 in)	388.6 mm (15.3 in)	223.8 mm (8.81 in)
PFCD1F128FLH1B	66 mm (2.60 in)	366.3 mm (14.42 in)	191.3 mm (7.53 in)
PFCD1F168FLH1B	67.3 mm (2.65 in)	366.3 mm (14.42 in)	214.6 mm (8.45 in)
PFCD1F128BWH1B	59.7 mm (2.35 in)	357.3 mm (14.07 in)	198.4 mm (7.81 in)
PFCD1F168BWH1B	59.7 mm (2.35 in)	357.3 mm (14.07 in)	198.4 mm (7.81 in)
PFCD1F128NLH1B	64.5 mm (2.54 in)	388.6 mm (15.3 in)	218.9 mm (8.62 in)
PFCD1F168NLH1B	64.5 mm (2.54 in)	388.6 mm (15.3 in)	223.8 mm (8.81 in)

Typical Flow Characteristics - 1cP fluid, 20 °C

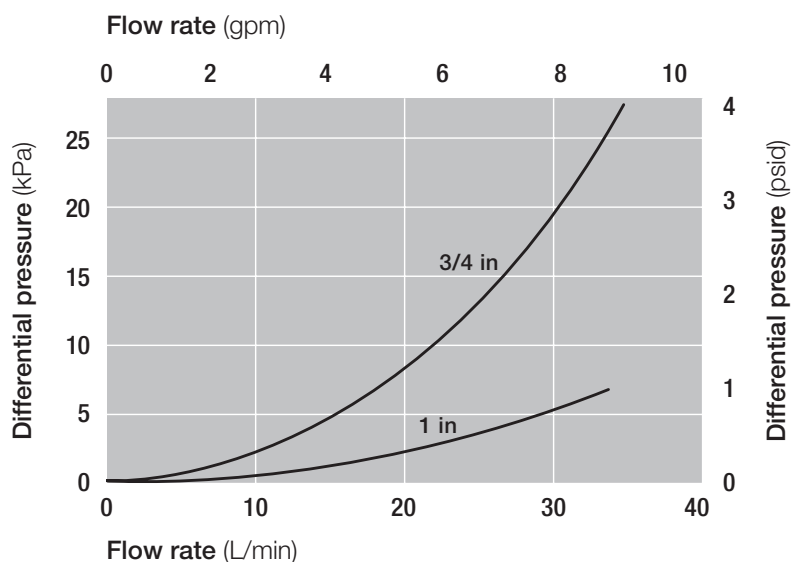

Part Numbers / Ordering Information

PFC D 1 2 3 4 5

Table 1

Code	Filter length
04	4 in
1	10 in
2	20 in

Table 2

Code	Closure nut materials
F	PVDF
P	PTFE

Table 3

Code	In / Out	Vent / Drain
128	3/4 in	1/2 in
168	1 in	1/2 in

Table 4

Code	Connections
BW	Butt Weld
FL	Flare style
SP	Pillar Super 300 P series
NL	Nano Link System

Table 5

Code	O-ring	Replacement Part
H1B	PFA encapsulated fluorocarbon elastomer	ORH1B-346
H36	FFKM Perfluoroelastomer	ORH36-346

* Part numbers are not available with every option. (Refer to codes for options.)
Contact your local Pall representative for option availability.

* SPANNER WRENCH PART NUMBER : ACS0655AAHD



Microelectronics

25 Harbor Park Drive
Port Washington, NY 11050
+1 516 484 3600 telephone
+1 800 360 7255 toll free US

Nihon Pall Ltd.

6-5-1, Nishishinjuku,
Shinjuku-ku
Tokyo 163-1325 Japan
+81 3 6901 5700 telephone
+81 3 5322 2109 fax

Pall Corporation has offices and plants throughout the world. To locate the Pall office or distributor nearest you, visit www.pall.com/contact.

The information provided in this literature was reviewed for accuracy at the time of publication. Product data may be subject to change without notice. For current information consult your local Pall distributor or contact Pall directly.

IF APPLICABLE Please contact Pall Corporation to verify that the product conforms to your national legislation and/or regional regulatory requirements for water and food contact use.

© Copyright 2025, Pall Corporation. Pall , FlexBow, Megaplast and Kleen-Change are trademarks of Pall Corporation. ® Indicates a trademark registered in the USA.

